

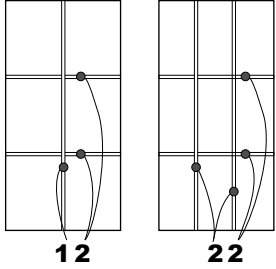

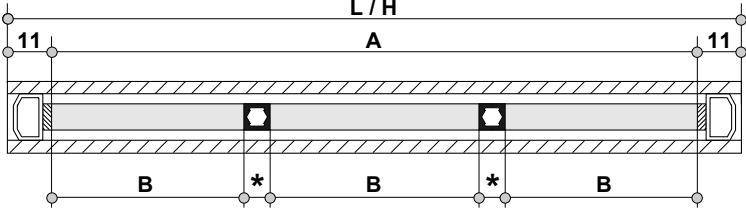



Tabella lavorazioni / Working table



DATA: DATE:	DITTA: FIRM:	ORDINE N°: ORDER NO:
CONSEGNA: DELIVERY:	INDIRIZZO: ADDRESS:	COMMESSA N°: WORK ORDER NO:

CODICE GRIGLIA GRILL CODE	SEZIONE VETROCAMERA E RIFERIMENTI CAVITY SECTION AND REFERENCES
Esempio: Example: 	 * art. 104  art. 105  art. 106 

FORMULE:

PROFILO PROFILE	TAGLIO RIF. "A" CUTTING REF. "A"	POSIZIONE RIF. "B" POSITION REF. "B"	CODICE GRIGLIA / GRILL CODE				
			1	2	3	4	5
 art. 104	L / H - 22	A - ...	8 : 2	16 : 3	24 : 4	32 : 5	40 : 6
 art. 105	L / H - 22	A - ...	16 : 2	32 : 3	48 : 4	64 : 5	80 : 6
 art. 106	L / H - 22	A - ...	24 : 2	48 : 3	72 : 4	96 : 5	120 : 6

VETROCAMERA RIF. "L / H" CAVITY REF. "L / H"		TAGLIO PROFILI RIF. "A" PROFILE CUTTING REF. "A"				POSIZIONE INCASTRO RIF. "B" PITCH POSITION REF. "B"	
Pezzi Pcs.	Dimensione vetrocamera Cavity dimensions	Tipo profilo Profile type	Cod. griglia Grill code	Pezzi Pieces	Lunghezza profilo Profile length	Asta millimetrata Millimetric rod	Griglie a passo variabile Grilles to variable pitch
5	L	470	104	2	(K) x Pezzi/Pcs. 10	448	144
	H	1118	RAL 9001	2	(K) x Pezzi/Pcs. 10	1096	360
	L			(J)	(K) x Pezzi/Pcs.		
	H			(K)	(J) x Pezzi/Pcs.		
	L			(J)	(K) x Pezzi/Pcs.		
	H			(K)	(J) x Pezzi/Pcs.		
	L			(J)	(K) x Pezzi/Pcs.		
	H			(K)	(J) x Pezzi/Pcs.		
	L			(J)	(K) x Pezzi/Pcs.		
	H			(K)	(J) x Pezzi/Pcs.		
	L			(J)	(K) x Pezzi/Pcs.		
	H			(K)	(J) x Pezzi/Pcs.		
	L			(J)	(K) x Pezzi/Pcs.		
	H			(K)	(J) x Pezzi/Pcs.		

(esempio example)